

FEATURES

- 1024 by 256 Pixel Format
- 26 μm Square Pixels
- Image Area 26.6 x 6.7 mm
- Wide Dynamic Range
- Symmetrical Anti-static Gate Protection
- Open Electrode Structure for Enhanced Quantum Efficiency
- Advanced Inverted Mode Operation
- Anti-blooming Readout Register
- Zero Light Emitting Output Amplifier

APPLICATIONS

- Spectroscopy
- Scientific Imaging
- TDI Operation

INTRODUCTION

The open electrode CCD30-11 is a high performance CCD sensor designed as an upgrade for the standard CCD30-11, for use in the scientific spectroscopy instrument market, where enhanced quantum efficiency is required at near-ultraviolet wavelengths. With an array of 1024 x 256 26 μm square pixels it has an imaging area to suit most spectrometer outputs of 26.6 x 6.7 mm (1.05 x 0.26 inch).

The readout register is organised along the long (1024 pixel) edge of the sensor and contains an anti-blooming drain to allow high speed binning operations of low level signals which may be adjacent to much stronger signals. The novel output amplifier design has no light emission.

Standard three phase clocking and buried channel charge transfer are employed and Inverted Mode Operation (IMO) is included as standard.

The open electrode CCD30-11 is packaged in a 20-pin DIL ceramic package and is pin compatible (but not completely clock compatible) with the standard CCD30-11.

Designers are advised to consult e2v technologies should they be considering using CCD sensors in abnormal environments or if they require customised packaging.

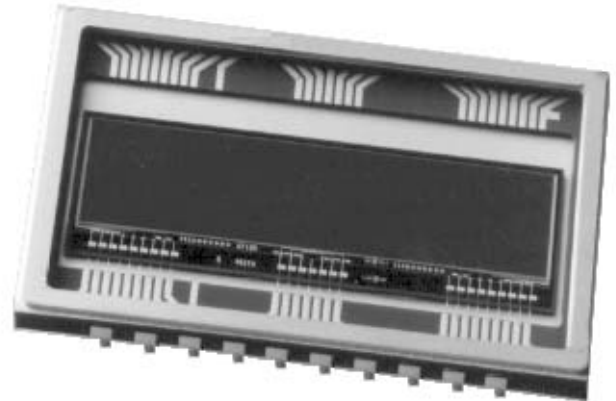

TYPICAL PERFORMANCE

Pixel readout frequency	20 - 1000	kHz
Output amplifier sensitivity	1.5	$\mu\text{V}/\text{e}^-$
Peak signal	300	ke^-/pixel
Dynamic range	75 000:1	
Spectral range	200 - 1060	nm
Readout noise (at 140 K, 20 kHz)	4	$\text{e}^- \text{ rms}$
QE at 700 nm	50	%
Peak output voltage	450	mV

GENERAL DATA

Format

Image area	26.6 x 6.7	mm
Active pixels (H)	1024	
(V)	256	
Pixel size	26 x 26	μm

Package

Package size	32.89 x 20.07	mm
Number of pins	20	
Inter-pin spacing	2.54	mm
Inter-row spacing	15.24	mm
Window material	quartz or removable glass	

PERFORMANCE

	Min	Typical	Max	
Peak charge storage (see note 1)	200k	300k	-	e ⁻ / pixel
Peak output voltage (unbinned)	-	450	-	mV
Dark signal at 293 K (see note 2)	-	250	500	e ⁻ / pixel/s
Charge transfer efficiency (see note 3):				
parallel	-	99.9999	-	%
serial	-	99.9993	-	%
Output amplifier sensitivity	1.3	1.8	2.3	μV/e ⁻
Readout noise at 140 K (see note 4)	-	4	6	rms e ⁻ / pixel
Readout frequency (see note 5)	-	20	5000	kHz
Response non-uniformity (std. deviation)	-	3	10	% of mean
Dark signal non-uniformity at 293 K (std. deviation)	-	100	200	e ⁻ / pixel/s
Output node capacity relative to image section	-	4.0	-	

ELECTRICAL INTERFACE CHARACTERISTICS

Electrode capacitances (measured at mid-clock level):

	Min	Typical	Max	
I _∅ /I _∅ interphase	-	2.0	-	nF
R _∅ /R _∅ interphase	-	70	-	pF
I _∅ /SS	-	11	-	nF
R _∅ /SS	-	185	-	pF
Output impedance	-	300	-	Ω

NOTES

- Signal level at which resolution begins to degrade.
- The typical average (background) dark signal at any temperature T (kelvin) between 230 and 300 K is given by:

$$Q_d/Q_{d0} = 1.14 \times 10^6 T^3 e^{-9080/T}$$

where Q_{d0} is the dark current at 293 K. Note that this is typical performance and some variation may be seen between devices. Below 230 K additional dark current components with a weaker temperature dependence may become significant.

- CCD characterisation measurements made using charge generated by X-ray photons of known energy.
- Measured using a dual-slope integrator technique (i.e. correlated double sampling) with a 10 μs integration period.
- Readout above 5000 kHz can be achieved but performance to the parameters given cannot be guaranteed.

BLEMISH SPECIFICATION

Traps Pixels where charge is temporarily held. Traps are counted if they have a capacity greater than 200 e⁻ at 233 K.

Slipped columns Are counted if they have an amplitude greater than 200 e⁻.

Black spots Are counted when they have a responsivity of less than 90% of the local mean signal illuminated at approximately half saturation.

White spots

Are counted when they have a generation rate 100 times the specified maximum dark signal generation rate at 293 K (measured between 233 and 273 K). The typical temperature dependence of white spot blemishes is different from that of the average dark signal and is given by:

$$Q_d/Q_{d0} = 122T^3 e^{-6400/T}$$

White column

A column which contains at least 9 white defects.

Black column

A column which contains at least 9 black defects.

GRADE	0	1	2
Column defects:			
black or slipped	0	1	6
white	0	0	0
Black spots:			
< 3 pixels	2	3	15
< 5 pixels	1	2	8
< 10 pixels	0	0	1
> 10 pixels	0	0	0
Traps > 200 e ⁻	1	2	5
White spots	10	10	15

Minimum separation between adjacent black columns 50 pixels

Note The effect of temperature on defects is that traps will be observed less at higher temperatures but more may appear below 233 K. The amplitude of white spots and columns will decrease rapidly with temperature.

TYPICAL OUTPUT CIRCUIT NOISE (Measured using clamp and sample)

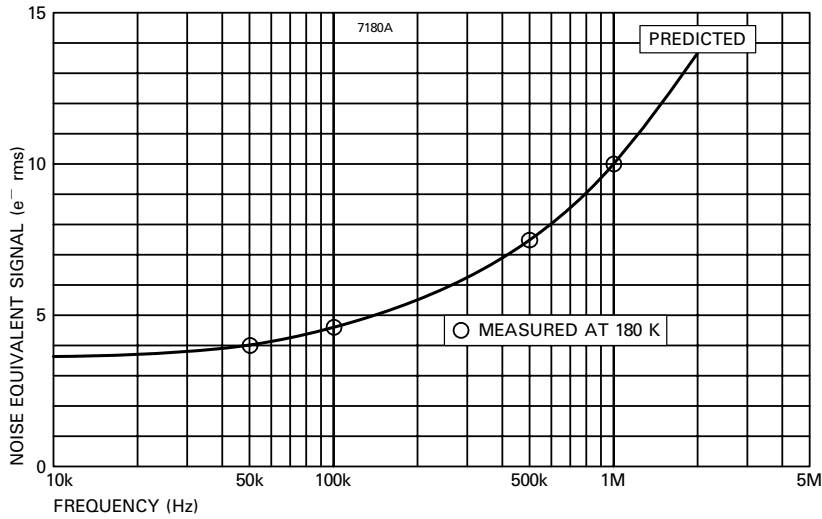

TYPICAL SPECTRAL RESPONSE (No window)

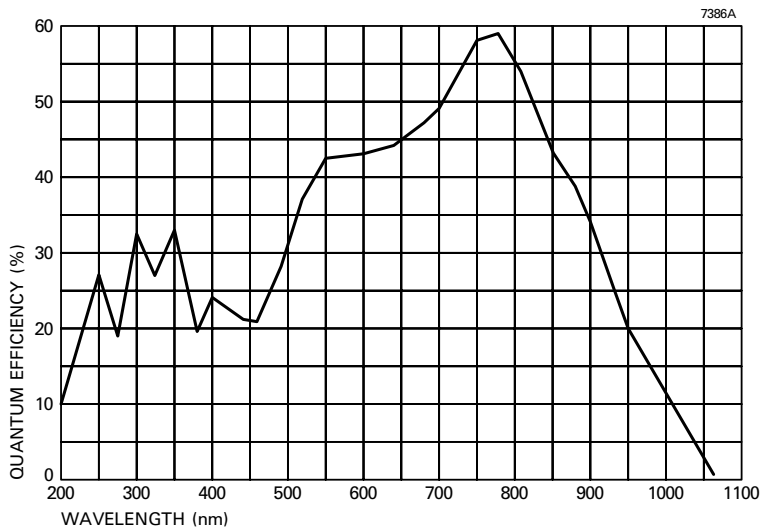

Note

UV QE varies rapidly with wavelength over the 200 to 400 nm range due to the thick AR coating.

TYPICAL VARIATION OF DARK SIGNAL WITH SUBSTRATE VOLTAGE

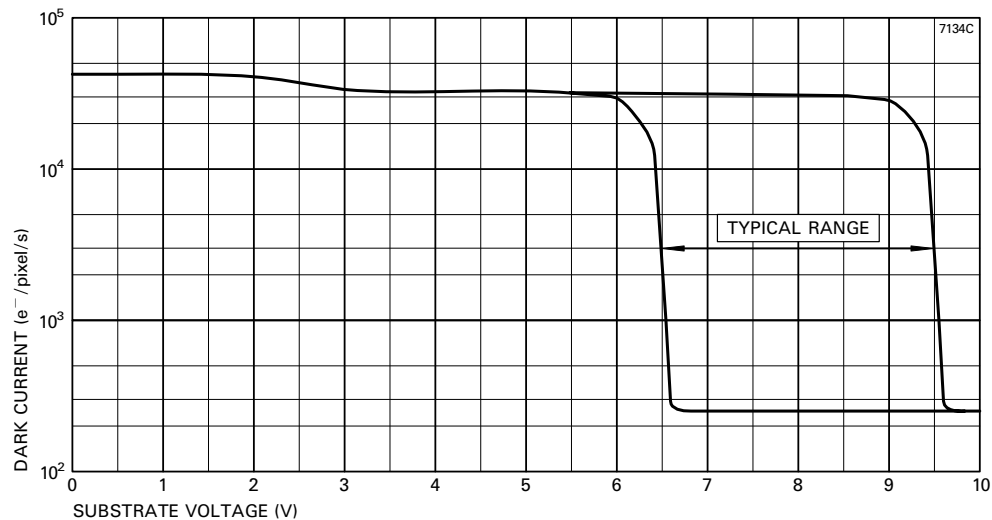

TYPICAL VARIATION OF DARK CURRENT WITH TEMPERATURE

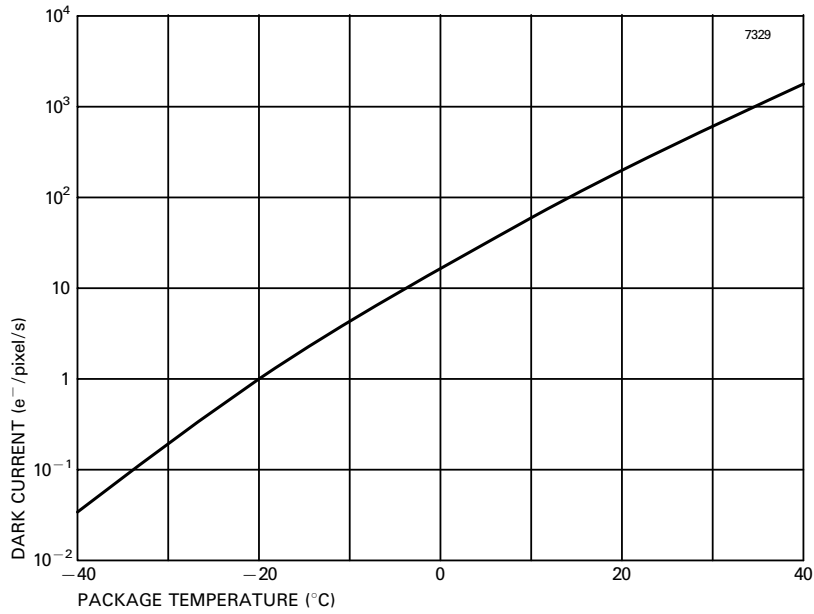

DEVICE SCHEMATIC

7135A

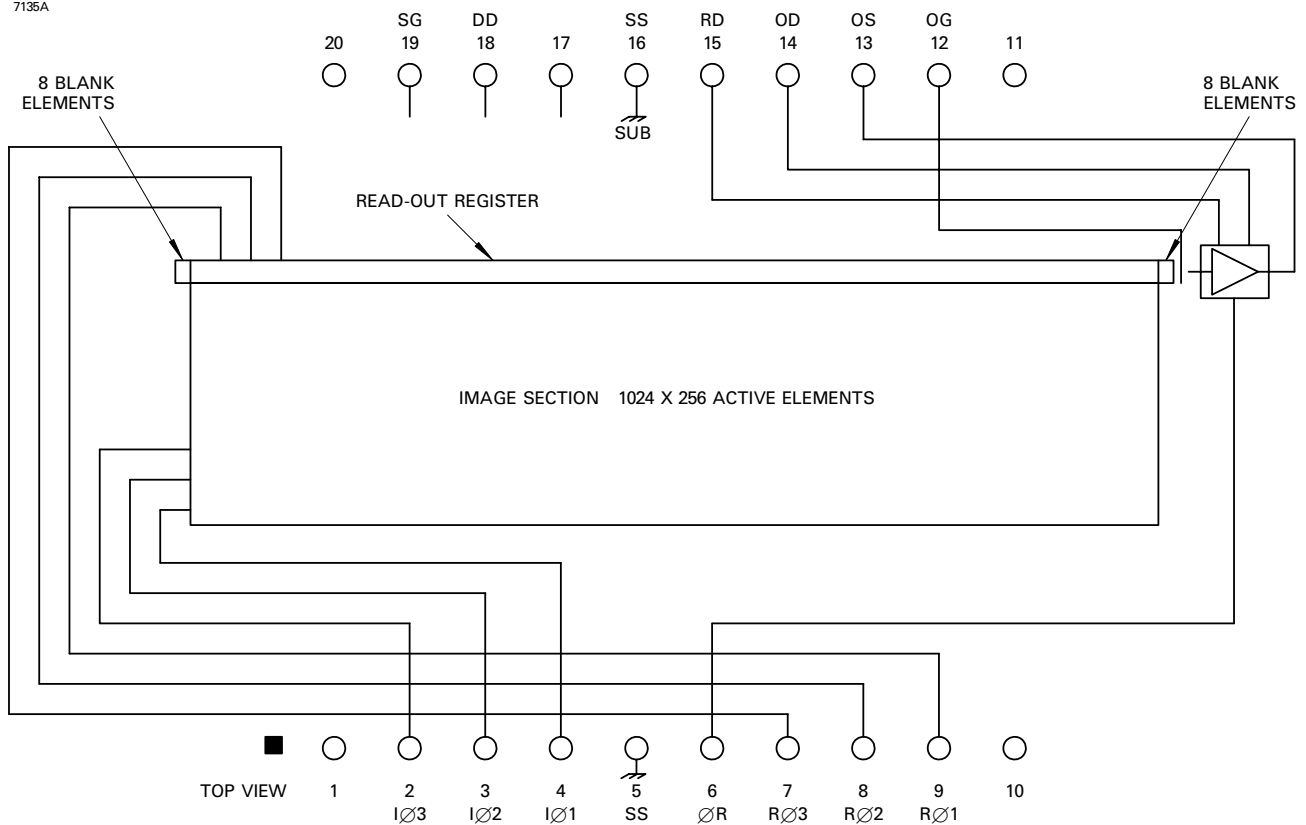

CONNECTIONS, TYPICAL VOLTAGES AND ABSOLUTE MAXIMUM RATINGS

PIN	REF	DESCRIPTION	PULSE AMPLITUDE OR DC LEVEL (V) (see note 6)			MAXIMUM RATINGS with respect to V_{SS}
			Min	Typical	Max	
1	-	No connection		-		-
2	IØ3	Image section, phase 3 (clock pulse)	10	12	15	± 20 V
3	IØ2	Image section, phase 2 (clock pulse)	10	12	15	± 20 V
4	IØ1	Image section, phase 1 (clock pulse)	10	12	15	± 20 V
5	SS	Substrate	8	9.5	11	-
6	ØR	Output reset pulse	10	12	15	± 20 V
7	RØ3	Readout register, phase 3 (clock pulse)	10	12	15	± 20 V
8	RØ2	Readout register, phase 2 (clock pulse)	10	12	15	± 20 V
9	RØ1	Readout register, phase 1 (clock pulse)	10	12	15	± 20 V
10	-	No connection	see note 7			-
11	-	No connection	see note 7			-
12	OG	Output gate	2	3.5	5	± 20 V
13	OS	Output transistor source	see note 8			-0.3 to +25 V
14	OD	Output drain	27	29	31	-0.3 to +25 V
15	RD	Reset transistor drain	17	18	19	-0.3 to +25 V
16	SS	Substrate	8	9.5	11	-0.3 to +25 V
17	-	No connection	-			-
18	DD	Diode drain	20	22	25	-0.3 to +25 V
19	SG	Spare gates	0	0	$V_{SS} + 19$	± 20 V
20	-	No connection	-			-

If all voltages are set to the 'typical' values, operation at or close to specification should be obtained. Some adjustment within the minimum - maximum range specified may be required to optimise performance.

Voltage between pairs of pins: OS to OD ± 15 V.

Maximum current through any source or drain pin: 10 mA.

OUTPUT CIRCUIT

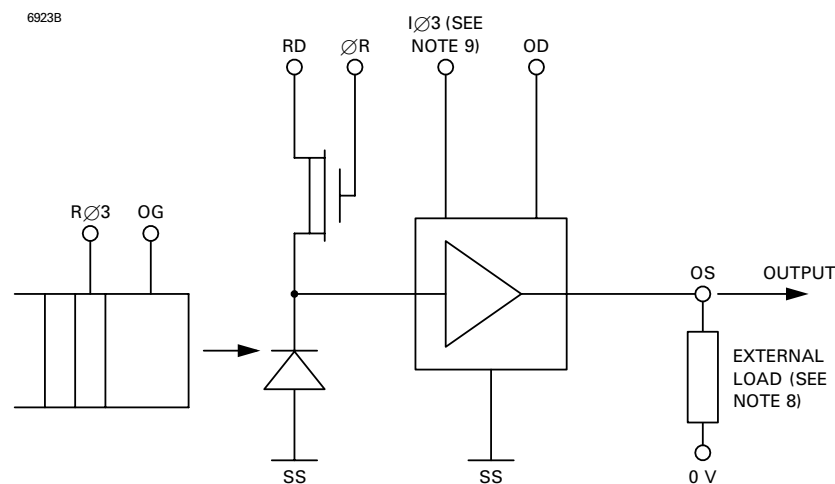

NOTES

- All pulse low levels 0 ± 0.5 V.
- There is no access to the temperature sensing diodes in the back-thinned version of the CCD30-11.
- Not critical; can be a 1 - 5 mA constant current source, or 5 - 10 k Ω resistor.
- The amplifier has a DC restoration circuit, which is activated internally whenever IØ3 is pulsed high.

FRAME READOUT TIMING DIAGRAM

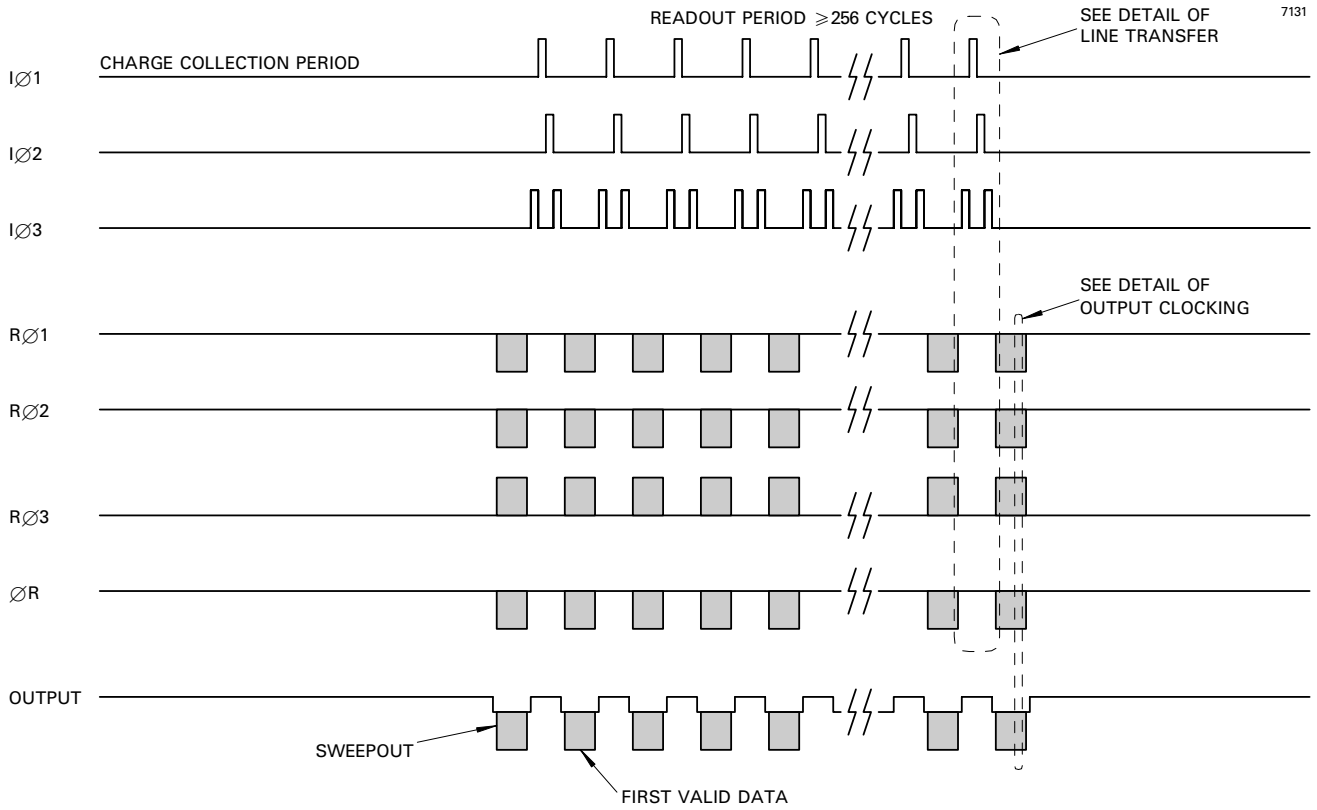

DETAIL OF LINE TRANSFER

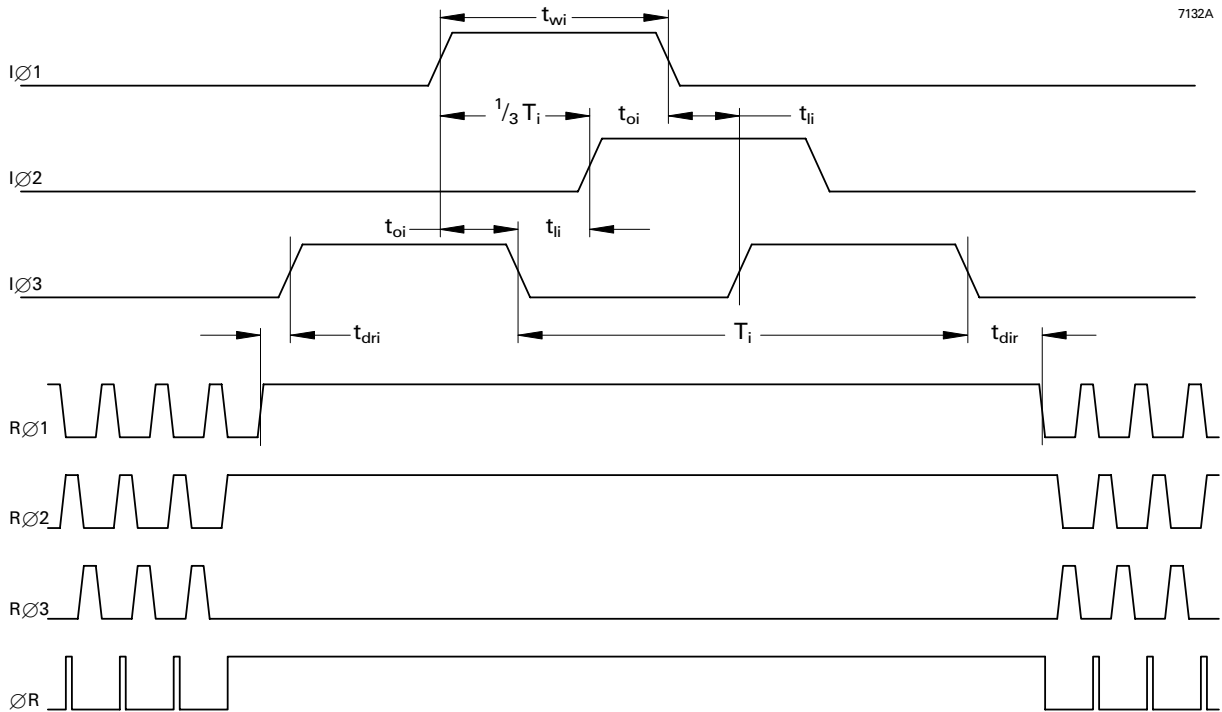

DETAIL OF OUTPUT CLOCKING

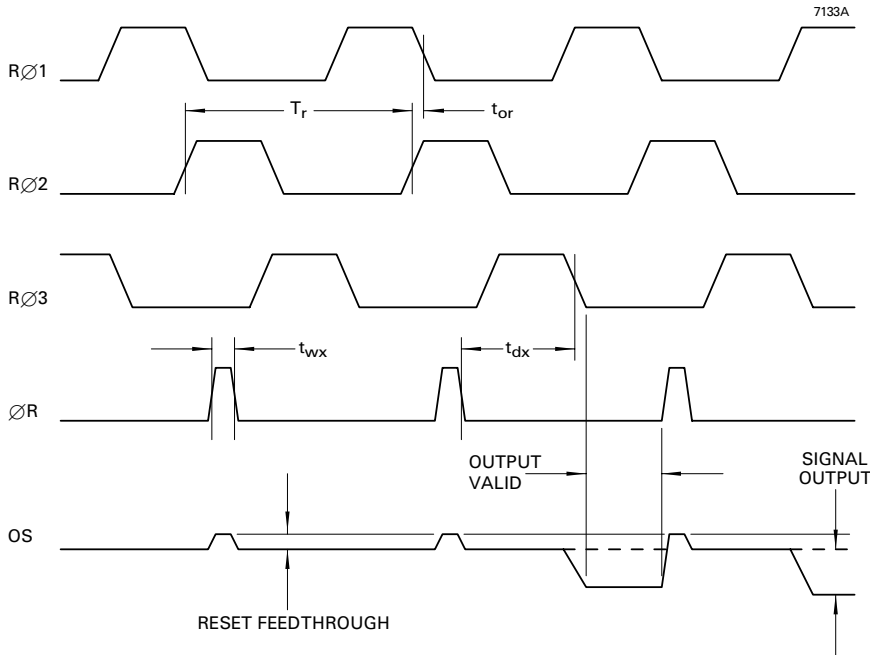

LINE OUTPUT FORMAT

7130A

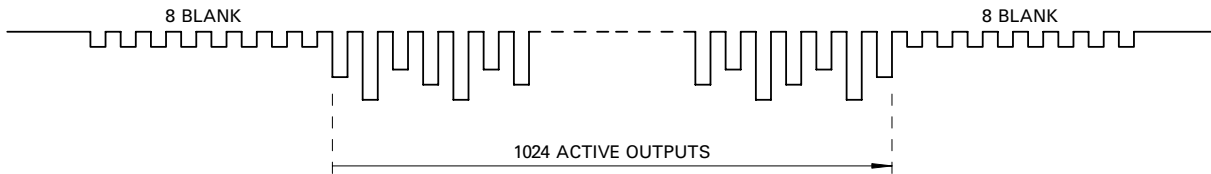

CLOCK TIMING REQUIREMENTS

Symbol	Description	Min	Typical	Max	
T_i	Image clock period	50	90	see note 10	μs
t_{wi}	Image clock pulse width	25	45	see note 10	μs
t_{ri}	Image clock pulse rise time (10 to 90%)	5	20	$0.5t_{oi}$	μs
t_{fi}	Image clock pulse fall time (10 to 90%)	t_{ri}	20	$0.5t_{oi}$	μs
t_{oi}	Image clock pulse overlap	3	10	$0.2T_i$	μs
t_{ij}	Image clock pulse, two phase low	2	10	$0.2T_i$	μs
t_{dir}	Delay time, IØ stop to RØ start	3	10	see note 10	μs
t_{dri}	Delay time, RØ stop to IØ start	1	2	see note 10	μs
T_r	Output register clock cycle period	200	see note 11	see note 10	ns
t_{rr}	Clock pulse rise time (10 to 90%)	50	$0.1T_r$	$0.3T_r$	ns
t_{fr}	Clock pulse fall time (10 to 90%)	t_{rr}	$0.1T_r$	$0.3T_r$	ns
t_{or}	Clock pulse overlap	20	$0.5t_{rr}$	$0.1T_r$	ns
t_{wx}	Reset pulse width	30	$0.1T_r$	$0.2T_r$	ns
t_{rx}, t_{fx}	Reset pulse rise and fall times	20	$0.5t_{rr}$	$0.2T_r$	ns
t_{dx}	Delay time, ØR low to RØ3 low	30	$0.5T_r$	$0.8T_r$	ns

NOTES

- No maximum other than that necessary to achieve an acceptable dark signal at the longer readout times.
- As set by the readout period.

OUTLINE

(All dimensions without limits are nominal)

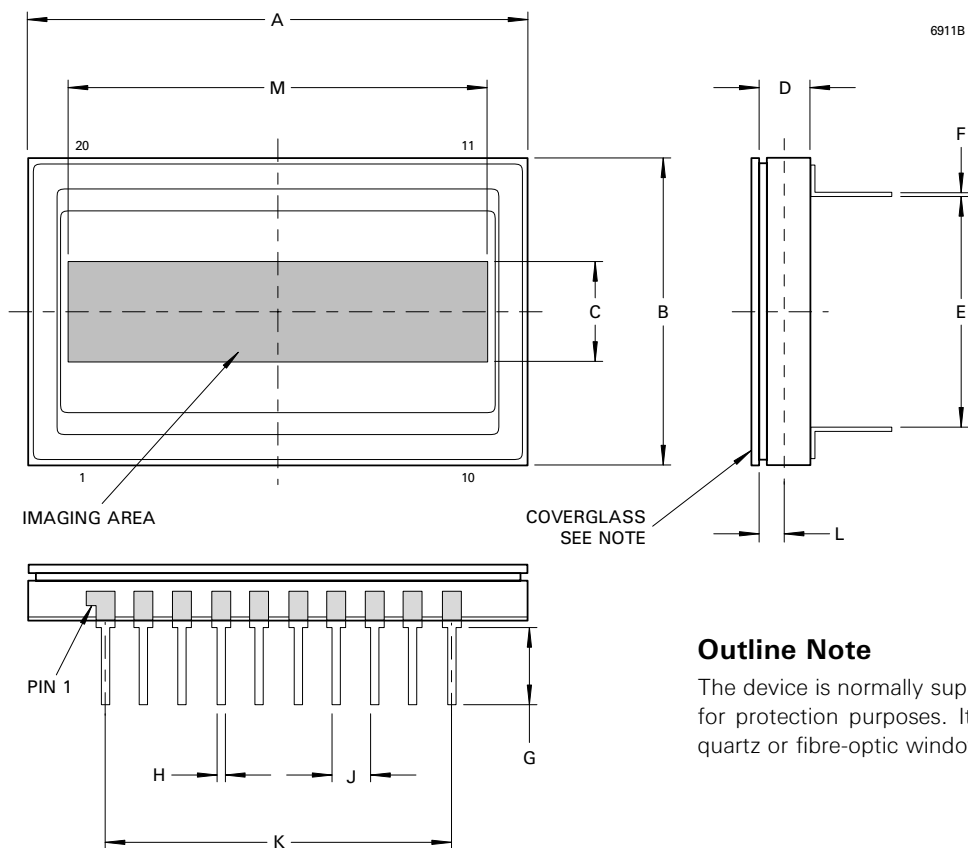

Outline Note

The device is normally supplied with a temporary glass window for protection purposes. It can also be supplied with a fixed, quartz or fibre-optic window where required.

Ref	Millimetres
A	32.89 ± 0.38
B	20.07 ± 0.25
C	6.7
D	3.30 ± 0.33
E	15.24 ± 0.25
F	$0.254 \begin{matrix} + 0.051 \\ - 0.025 \end{matrix}$
G	5.21
H	0.46 ± 0.05
J	2.54 ± 0.13
K	22.86 ± 0.13
L	1.65 ± 0.56
M	26.6

ORDERING INFORMATION

Options include:

- Temporary Quartz Window
- Permanent Quartz Window
- Temporary Glass Window

For further information on the performance of these and other options, please contact e2v technologies.

HANDLING CCD SENSORS

CCD sensors, in common with most high performance MOS IC devices, are static sensitive. In certain cases a discharge of static electricity may destroy or irreversibly degrade the device. Accordingly, full antistatic handling precautions should be taken whenever using a CCD sensor or module. These include:-

- Working at a fully grounded workbench
- Operator wearing a grounded wrist strap
- All receiving socket pins to be positively grounded
- Unattended CCDs should not be left out of their conducting foam or socket.

Evidence of incorrect handling will invalidate the warranty. All devices are provided with internal protection circuits to the gate electrodes (pins 2, 3, 4, 6, 7, 8, 9, 12, 19) but not to the other pins.

HIGH ENERGY RADIATION

Device characteristics will change when subject to ionising radiation.

Users planning to operate CCDs in high radiation environments are advised to contact e2v technologies.

TEMPERATURE LIMITS

	Min	Typical	Max	
Storage	73	-	373	K
Operating	73	233	323	K

Operation or storage in humid conditions may give rise to ice on the sensor surface, causing irreversible damage.

Device heating/cooling 5 K/min max

Whilst e2v technologies has taken care to ensure the accuracy of the information contained herein it accepts no responsibility for the consequences of any use thereof and also reserves the right to change the specification of goods without notice. e2v technologies accepts no liability beyond that set out in its standard conditions of sale in respect of infringement of third party patents arising from the use of tubes or other devices in accordance with information contained herein.